

SECTION E-E
SCALE 1:1

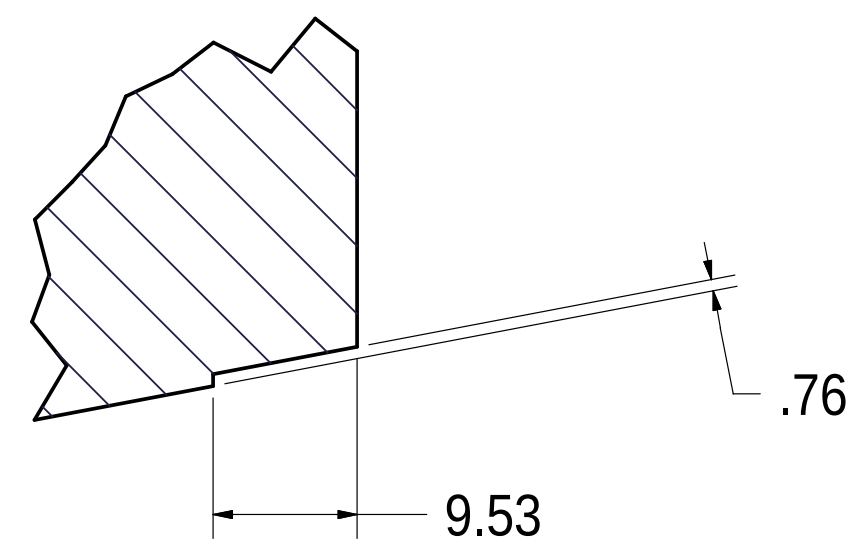

DETAIL B
SCALE 2:1

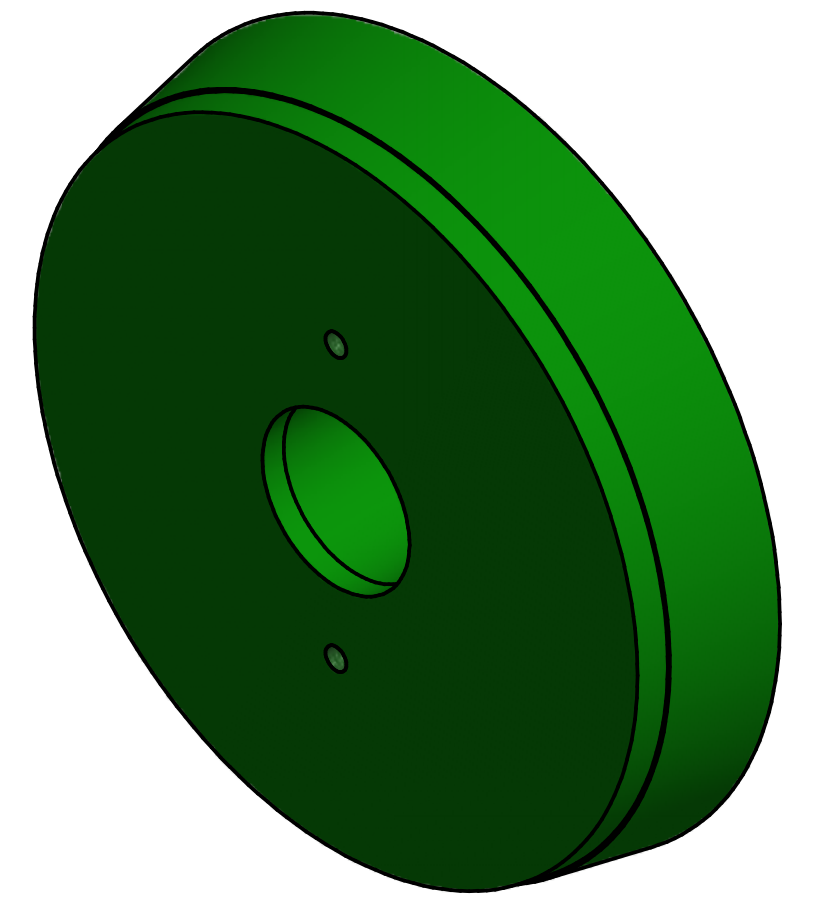
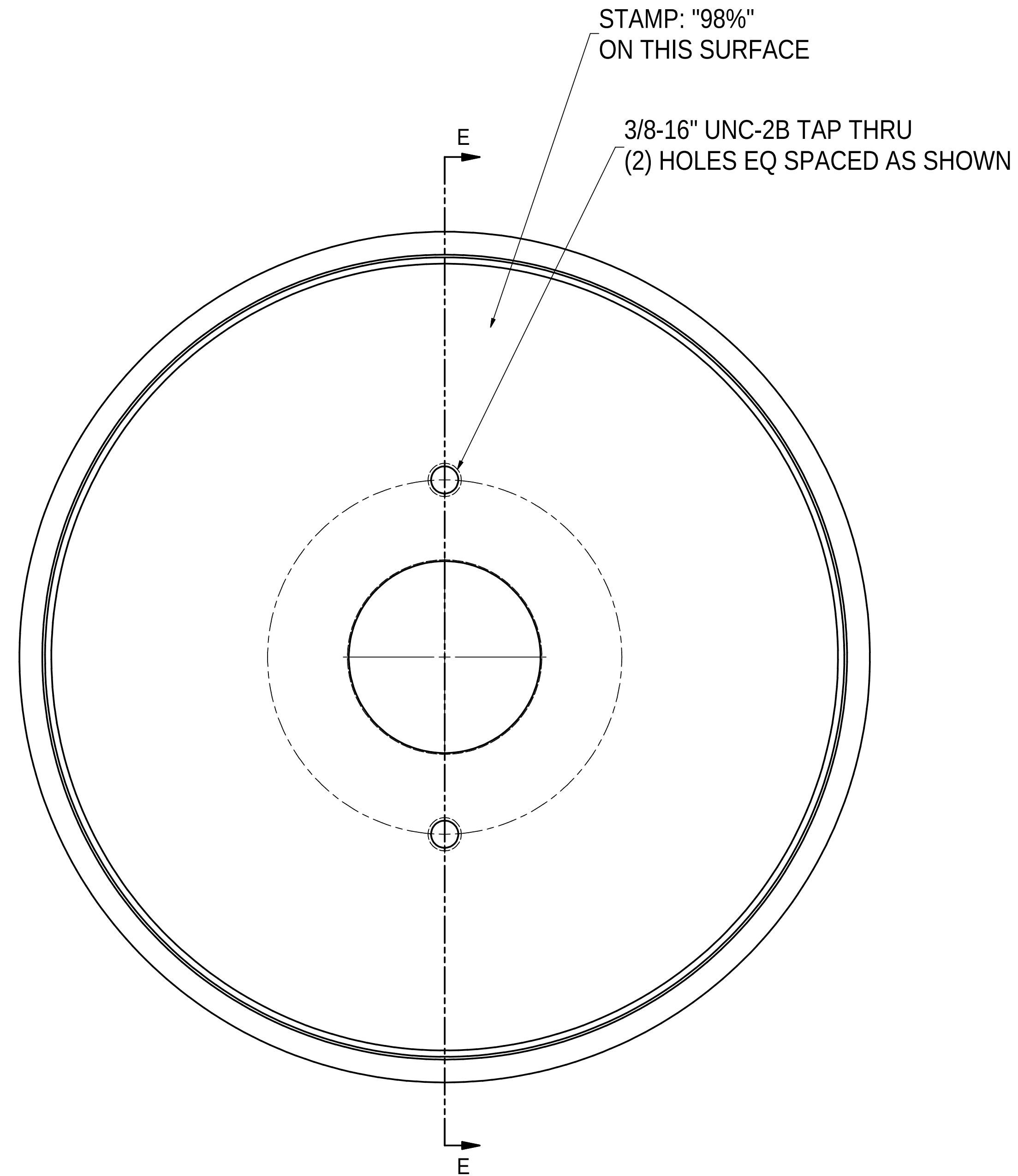

ISO VIEW
SCALE- 1:2

- NOTES:
 1. BREAK ALL SHARP EDGES AND CORNERS
 2. FINISH- NONE

GEOMETRIC DIMENSIONING AND TOLERANCING
 CONFORMS TO ANSI Y14.5

REVISION HISTORY			
REV	DESCRIPTION	DATE	APPROVED
MATERIAL	AISI D2	DATE	9/6/2008
HEAT TREAT	Rc 58-62	DRAWN BY	
TOOL CODE	07-13-32	CHECKED BY	
ANGULAR DIMENSION ±1° TWO PLACE DECIMALS ±0.010 THREE PLACE DECIMALS ±0.005 FRACTIONS ±1/32 UNLESS OTHERWISE NOTED		SCALE	1:1
		PART No.	N/A
		DRAWING No.	

INNER
 DRIVE-HM133401
 ROLLER
 WORKHEAD ASSEMBLY